

INSTRUCTIONS FOR USE

Micro-electric pump 3417000 DROPSA SpA

In accordance with point 1.7.4, to I, Dir 98/37/CE

Sections:

- 0.0 INTRODUCTION
- 1.0 DESCRIPTION OF THE PUMP
- 2.0 TECHNICAL SPECIFICATIONS
- 3.0 CORRECT USE
- 4.0 INSTRUCTIONS FOR ORDERING
AND DISTRIBUTORS

DECLARATION OF CONFORMITY



Catalogue P/N C2015IE - Wk 26/07

| | |
|----------------------------|---|
| Registered name | DROPSA SpA |
| Address | via Croce 1, 20090 Vimodrone (MI) Italy |
| Model | Micro-electric pump type 3417000 |
| Year of manufacture | 1999 |
| Marking | CE |

0.0 INTRODUCTION

This user's and maintenance manual refers to a **micro-electric pump**, for use in mineral oil lubrication systems. It is recommended that this manual is carefully kept in good condition and is always available to persons requiring to consult it.

To request further copies, updates or clarifications with respect to this manual contact the Engineering Department at Dropsa SpA.

The use of the pump referred to in this manual must be entrusted to qualified personnel with a knowledge of basic mechanics, hydraulics and electrical systems.

The manufacturer reserves the right to update the product and/or the user's manual without the obligation to revise previous versions. It is however, possible to contact the Engineering Department for the latest revision in use.

The pump, and any accessories mounted on it, should be carefully checked immediately on receipt and in the event of any discrepancy or complaint the Dropsa SpA Sales Department should be contacted without delay.

DROPSA S.p.A. declines to accept any responsibility for injuries to persons or damage to property in the event of

the non-observance of the information presented in this manual.

Any modification to component parts of the system or the different destination of use of this system or its parts without prior written authorisation from DROPSA S.p.A. will absolve the latter from any responsibility for injury or damage to persons and/or property and will release them from all obligations arising from the guarantee.

Instructions for the correct ordering of the required model, and a list of importers, is shown in Section 4.

1.0 DESCRIPTION OF THE PUMP

This range of pumps is particularly suitable for use on lubrication systems, with a working pressure of 4 bar.

The pump can be provided with or without a tank, is cam actuated and a spring controlled piston; it is made up of an electric motor, a tank (where specified), a suction filter and one for loading with oil, and an electric minimum level contact.

1.1 Micro-electric pump

The pump is cam actuated and the piston is spring controlled. The cycle time is fixed and is determined by the type of reducer fitted to the electric motor. The flow rate varies between 1cc. and 0.2cc. The operating pressure is 4 bar. It is suitable for oil with a viscosity of 250 cSt at a fluid working temperature between +5 °C and +40 °C.

Should it be required to use a different specification product, prior authorisation should be obtained from Dropsa S.p.A.

1.2 Electric Motor

Single phase motor 50-60 Hz, 24, 110 or 220 V. the absorbed power is 2.5 W – 3.5 VA at 50 Hz and 2 W – 2.5 VA at 60 Hz. Admissible voltage variation is $\pm 10\%$.

| | | |
|-----------------------------|----------------------|--------------------------|
| grade of protection - IP 40 | insulation class - F | continuous service - YES |
|-----------------------------|----------------------|--------------------------|

1.3 Tank

| Version | Dimensions wxdxh (mm) | Weight (Kg) |
|---------------------------------------|-----------------------|-------------|
| 1 litre white semi-transp. plastic | 160x116x183 | 0.685 |
| 1.7 litre white semi-transp. plastic. | 194x115x234 | 0.315 |

1.4 Minimum level indicator

Magnetic type

Reversible float with contact normally open at rest. To convert to normally closed contact turn the float upside down. The maximum power is 50 W \div 50 VA; the maximum voltage is 220 V ac – 150 V dc.

1.5 Suction filter

Filtration grade 260 micron

2.0 TECHNICAL SPECIFICATIONS

2.1 Fixing and overall dimensions

1 LT. TANK

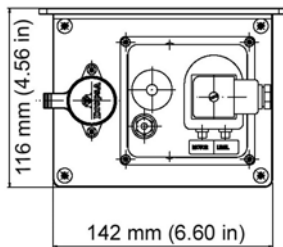
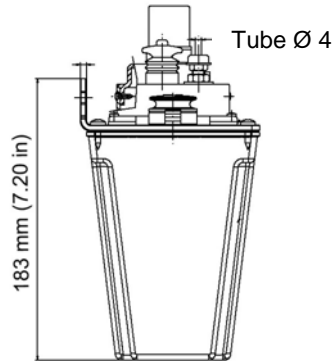
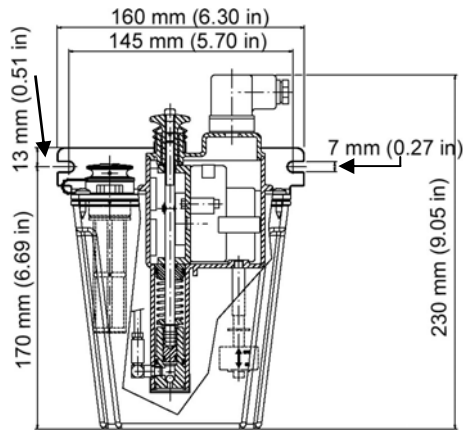

1.7 LT.

TANK

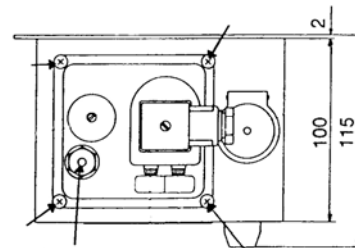
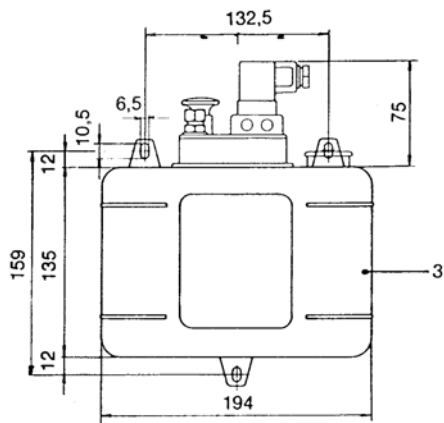

Uscita lubrificante per tubo Ø 4
Lubricant outlet for 4 mm tube

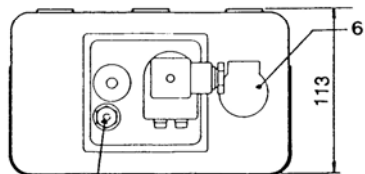

Uscita lubrificante per tubo Ø 4
Lubricant outlet for 4 mm tube

2.2 Electrical system - Technical Data

| | |
|--------------------------|--|
| Electrical power supply: | 24, 110, 220 Vac 50 - 60 Hz Single phase |
| Absorbed power: | max 2.5 W |

2.3 Other data

| | |
|------------------------------------|--------------------|
| Class of protection | F |
| Grade of mechanical protection | IP 54 |
| Working temperature | -15 - + 60 °C |
| Operating humidity | 90 % rel. humidity |
| Preservation temperature | - 30 - + 90 °C |
| Level of continuous sound pressure | < 70 dB(A) |

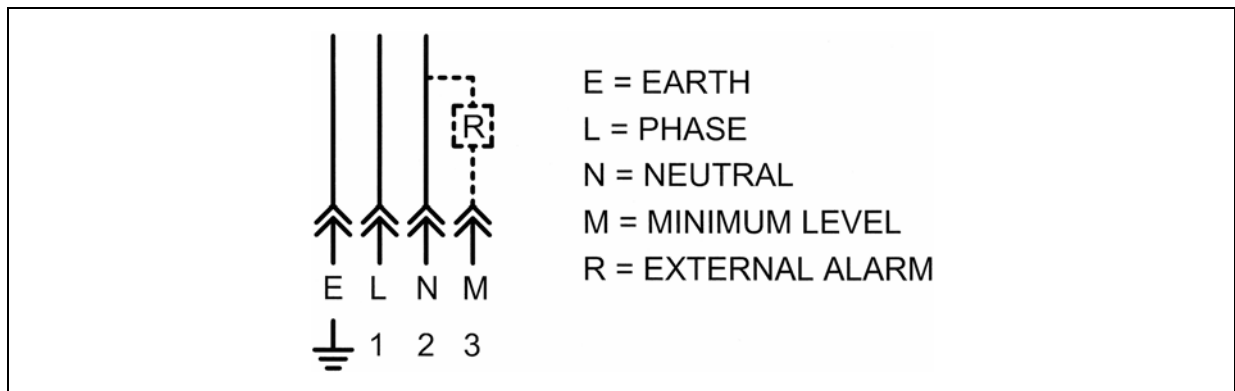

3.0 CORRECT USE

3.1 Putting into service

Damage to the power supply cable and housing can lead to contact with high voltage parts and present a danger to life:

- ◆ Check the integrity of the power supply cable and the unit prior to use.
- ◆ Where the cable or the unit is damaged do not operate the equipment!
- ◆ Replace the power supply cable with a new one.
- ◆ The unit should be opened and repaired ONLY by qualified personnel.

- ◆ In order to prevent the danger of electric shock due to direct or indirect contact with live parts, it is necessary that the electrical power supply line is adequately protected by a suitable differential magneto-thermal switch with an intervention threshold of 0.03 Ampere and a maximum intervention time of 1 second.
The switching power of the circuit breaker must be = 10 kA and the nominal current $I_n = 6 A$.
- ◆ The pump MUST NOT be submersed in fluids or utilised in environments which are particularly aggressive or explosive/inflammable if not prepared for this purpose beforehand by the supplier.
- ◆ For correct fixing verify the distance between centres shown in the diagram in Section 2.
- ◆ Use gloves and safety glasses as required in the lubrication oil safety chart.
- ◆ DO NOT use aggressive lubricants with NBR gaskets and seals; if in doubt consult the Engineering Department of Dropsa SpA, who will provide a chart with the details of recommended oils.
- ◆ DO NOT ignore dangers to health and observe all hygiene standards.
- ◆ WARNING! All electrical components must be grounded. This refers to both electrical components and control devices. In this regard ensure that the ground cable is correctly connected. For reasons of safety the ground cable must be approx. 100 mm longer than the phase cables. In the event of accidental detachment of the cable, the ground terminal must be the last to be removed.

Action to be taken prior to start up

- ◆ Verify the integrity of the pump;
- ◆ Fill the tank with suitable lubricant (min/max indication on the tank);
- ◆ Ensure the pump is at working temperature and the tubing is free of air bubbles;
- ◆ Ensure that any electrical connections have been effected correctly (CEI 64/8, IEC 364);
- ◆ Check the connections of any level and solenoid valve to the control panel;
- ◆ With the pump started, check the direction of rotation of the electric motor: if the electric motor is rotating anticlockwise invert the cable connections.

⊕ Unless otherwise specified, the minimum level state is supplied with the contacts closed for minimum level. Where the user requires the contacts to be normally open, with the tank open simply invert the direction of operating of the float.

3.2 Use

1. verify the settings made;
2. press the start button of the machine to which the micro-electric pump is connected;
3. verify the starting of the pump;
4. verify the adequate lubrication of the machine (if doubt exists as to the correct functioning consult the Engineering Department of Dropsa SpA to request test procedures).

3.3 Transport and storage

Transport and storage is effected in a cardboard packing.

No particular precautions are required except as noted on the packing itself.

Handling can be effected by one person.

! *Lift the equipment observing the right way up shown on the cardboard packaging.*

! *The machine components can withstand temperatures, during storage, from -20 to +50°C; however, in order to avoid damage, starting of the machine should occur at a minimum temperature of -5°C.*

3.4 Assembly/Disassembly

No pump assembly operations are envisaged.

For wall mounting ensure adequate space is available (as shown in the installation diagram) to avoid abnormal postures and possible impacts; fixing holes are provided with different characteristics depending on the version (see section 2)

Subsequently it will be necessary, as previously described, to connect the pump to the machine hydraulically and then to connect the control panel.

During the disassembly phase ensure the tank is empty.

Disconnect the electrical and hydraulic parts.

Where the machine is to be scrapped, do not dispose of potentially polluting parts in the environment, following local regulations for their correct disposal.

At the time of the machine being scrapped it is necessary to remove and destroy the identification plate and all other relative documents.

3.5 Regulation

The only parameter which can be modified is the flow rate; turn the regulating knob clockwise to increase and anticlockwise to decrease the rate.

3.6 Maintenance

! *Locate the machine in conditions which facilitate easy access.*

! *Utilise individual protection to avoid contact with the lubricant*

Periodical inspection

Periodically it is necessary to check:

VERIFICATION

The state of lubrication
 The oil level
 Cleanliness of the loading and suction filters
 The cleaning of the bottom of the tank if deposits are present

WORK CYCLES

1000
 2000
 4000
 6000

The machine does not require any special tools to carry out checks or maintenance tasks, However, it is recommended that only tools suitable for the tasks and in good condition should be utilised (DPR 547/55) to avoid injury to persons or damage to machine parts.

3.7 Repairs

The following diagnostic table indicates the main anomalies which may be encountered, the probable causes and possible solutions.

The anomalies shown are:

- the pump fails to deliver lubricant in sufficient quantities or not at all;
- the pump fails to deliver lubricant at the prescribed pressure

In case of doubts and/or problems which cannot be resolved do not attempt to disassemble parts of the machine but contact the Engineering Department of DROPSA S.p.A.

| DIAGNOSTIC TABLE | | |
|--|--|---|
| ANOMALY | PROBABLE CAUSE | REMEDY |
| The pump does not deliver oil or does not deliver the exact prescribed quantities | <ul style="list-style-type: none"> • Drawing air because the tank is empty • The intake filter is dirty or blocked • The internal connections have loosened • Pump has deteriorated • Pump element valve is dirty or broken | <ul style="list-style-type: none"> • Refill the tank and vent the air from the system • Wash the filter with kerosene and blow through with compressed air • Tighten all the connections ensuring there are no leaks • Replace the pump • Clean or replace the valve |
| The pump fails to deliver oil at the prescribed pressure | <ul style="list-style-type: none"> • Suction valve dirty or delivery tubing damaged | <ul style="list-style-type: none"> • Clean the valve and replace the delivery tubing |

3.8 Dangers present in use

The verification of conformity with the essential safety requirements and regulations of the Machine Directive is effected by means of the compilation of a check list which has been pre-prepared and is contained in the *technical file*.

The lists which are utilised are of three types:

- list of dangers (as in EN 414 referring to EN 292)
- application of essential safety requirements (Machine Dir. - att. 1, part 1)
- electrical safety requirements (EN 60204-1.)

The following is a list of dangers which have not been fully eliminated but which are considered acceptable:

- ◆ contact with oil -> see the requirements for the use of suitable personal protective clothing
- ◆ use of unsuitable lubricant -> the characteristics of the fluid are shown on the pump and in the manual

(in case of doubt contact the Eng. Dept of Dropsa Spa)

- ◆ protection against direct and indirect contact must be provided by the user
- ◆ given the purpose of the pump it must always be functioning; for this reason it is necessary to pay attention to the electrical connections which, in the case of a power failure, the customer's machine is restarted only by means of a reset, while the lubrication pump is able to restart automatically.

| INADMISSIBLE FLUIDS | |
|--|--|
| Fluids | Danger |
| Lubricants with abrasive additives | High wear rate of contacted parts |
| Lubricants with silicone based additives | Seizure of the pump |
| Petrol – solvents – inflammable liquids | Fire – explosion – damage to seals |
| Corrosive products | Corrosion of the pump– injury to persons |
| Water | Oxidation of the pump |
| Food substances | Contamination of the substances themselves |

4.0 INSTRUCTIONS FOR ORDERING AND DISTRIBUTORS

| Motor voltage | Motor part N° | Lubrication interval. (min.) | | 5 cc Pump + 1.1 lt. tank | 5 cc pump + 1.7 lt. tank | 1 cc pump + 1.7 lt. tank | 1 cc pump + 1.1 lt. tank | 5 cc pump | 1 cc pump |
|-----------------------|---------------|------------------------------|-------|--------------------------|--------------------------|--------------------------|--------------------------|-----------|-----------|
| | | 50 Hz | 60 Hz | | | | | | |
| 24 V 50 - 60 Hz | 3301339 | 5 | 4.16 | 3417151 | 3417047 | 3417116 | 3417111 | 3417061 | 3417131 |
| | 3301340 | 10 | 8.3 | 3417152 | 3417048 | 3417117 | 3417112 | 3417062 | 3417132 |
| | 3301341 | 30 | 25 | 3417153 | 3417049 | 3417118 | 3417113 | 3417063 | 3417233 |
| | 3301342 | 60 | 50 | 3417154 | 3417050 | 3417119 | 3417114 | 3417064 | 3417234 |
| | 3301343 | 120 | 100 | 3417155 | 3417051 | 3417120 | 3417115 | 3417065 | 3417235 |

| Motor voltage | Motor part N° | Lubrication interval. (min.) | | 5 cc Pump + 1.1 lt. tank | 5 cc pump + 1.7 lt. tank | 1 cc pump + 1.7 lt. tank | 1 cc pump + 1.1 lt. tank | 5 cc pump | 1 cc pump |
|------------------------|---------------|------------------------------|-------|--------------------------|--------------------------|--------------------------|--------------------------|-----------|-----------|
| | | 50 Hz | 60 Hz | | | | | | |
| 110 V 50 - 60 Hz | 3301325 | 5 | 4.16 | 3417156 | 3417042 | 3417136 | 3417106 | 3417056 | 3417126 |
| | 3301327 | 10 | 8.3 | 3417157 | 3417043 | 3417137 | 3417107 | 3417057 | 3417127 |
| | 3301329 | 30 | 25 | 3417158 | 3417044 | 3417138 | 3417108 | 3417058 | 3417128 |
| | 3301331 | 60 | 50 | 3417159 | 3417045 | 3417139 | 3417109 | 3417059 | 3417129 |
| | 3301333 | 120 | 100 | 3417160 | 3417046 | 3417140 | 3417110 | 3417060 | 3417130 |

| Motor voltage | Motor part N° | Lubrication interval. (min.) | | 5 cc Pump + 1.1 lt. tank | 5 cc pump + 1.7 lt. tank | 1 cc pump + 1.7 lt. tank | 1 cc pump + 1.1 lt. tank | 5 cc pump | 1 cc pump |
|------------------------|---------------|------------------------------|-------|--------------------------|--------------------------|--------------------------|--------------------------|-----------|-----------|
| | | 50 Hz | 60 Hz | | | | | | |
| 220 V 50 - 60 Hz | 3301326 | 5 | 4.16 | 3417161 | 3417036 | 3417141 | 3417101 | 3417035 | 3417121 |
| | 3301328 | 10 | 8.3 | 3417162 | 3417037 | 3417142 | 3417102 | 3417052 | 3417122 |
| | 3301330 | 30 | 25 | 3417163 | 3417038 | 3417143 | 3417103 | 3417053 | 3417123 |
| | 3301332 | 60 | 50 | 3417164 | 3417039 | 3417144 | 3417104 | 3417054 | 3417124 |
| | 3301334 | 120 | 100 | 3417165 | 3417041 | 3417145 | 3417105 | 3417055 | 3417125 |

REPLACEMENT PARTS

Suction filter: Part N° 3130074

Oil loading filter: Part N° 3130101

CE Declaration Of Conformity

| |
|--|
| Manufacturer: DROPSA SpA Company Via Croce, 1 - 20090 Vimodrone (MI), Italy Address +39 02 250791 Telephone |
|--|

It is certified that:

| |
|---|
| The machine: <u>Micro-electric pump type 3417000</u> |
|---|

- * is manufactured in conformity with the DIRECTIVE OF THE COUNCIL OF THE EUROPEAN COMMUNITY concerning the harmonisation of member states legislation relative to machines (98/37/CE), EMC (89/336/CEE) and BT (73/23/CEE) and relative amendments.
- * is manufactured in accordance with the following standards and harmonised technical specifications:
EN 292/1, EN 292/2, EN 50081-2, EN 50082-2, CEI EN 60204-1, EN 1050.

| | |
|--|--------------------|
| Technical Manager | Ing. Walter Divisi |
| Product Manager | Name |
| DROPSA SpA - Vimodrone (MI) - Italy | |
| Company | |
|  | January 1999 |
| Signature | Date |

DropsA Spa

ITALY
Dropsa SpA
t.(+39) 02-250791
f.(+39) 02-25079767

SPAIN
Polydrop, S.A.
t.(+34) 93-260-22-50
f.(+34) 93-260-22-51

U.S.A.
Dropsa Corporation
t.(+1) 586-566-1540
f.(+1) 586-566-1541

U.K.
Dropsa (UK) Ltd
t.(+44) 01784-431177
f.(+44) 01784-438598

BRAZIL
Dropsa
t.(+55) 011-563-10007
f.(+55) 011-563-19408

GERMANY
Dropsa GmbH
t.(+49) 0211-394-011
f.(+49) 0211-394-013

AUSTRALIA
Dropsa Australia Ltd.
t.(+61) 02-9938-6644
f.(+61) 02-9938-6611

FRANCE
Dropsa Ame
t.(+33) 01-3993-0033
f.(+33) 01-3986-2636